

Paddle Blade Agitator Specifications and Dimensions

STANDARD FEATURES:

- 5 HP through 20 HP
- Driven by a explosion proof (XP), 230/460 V, 3 Ph, 50/60 Hz, inverter duty motor
- Mixing head hydraulically raised by a air/oil hydraulic lift
- Bow-Tie Blade or Paddle Blade
- Stainless Steel type 304 wetted parts
- All non-Stainless Steel external surfaces coated with a white two-part epoxy
- Clamping device to secure mix vessel

AVAILABLE OPTIONS:

- Laboratory sized equipment from 1/2 HP to 2 HP available
- Various diameter mixing blades
- Larger horsepower designs available
- Sanitary design with special polishes and custom enclosures
- Custom mix vessels designed and built to desired specifications
- Cover to seal mix chamber
- Tank mounted designs available
- Special motors including explosion proof, Stainless Steel, wash-down and various voltages and frequencies
- Controls including variable frequency drives, explosion proof operator stations and Human Machine Interfaces

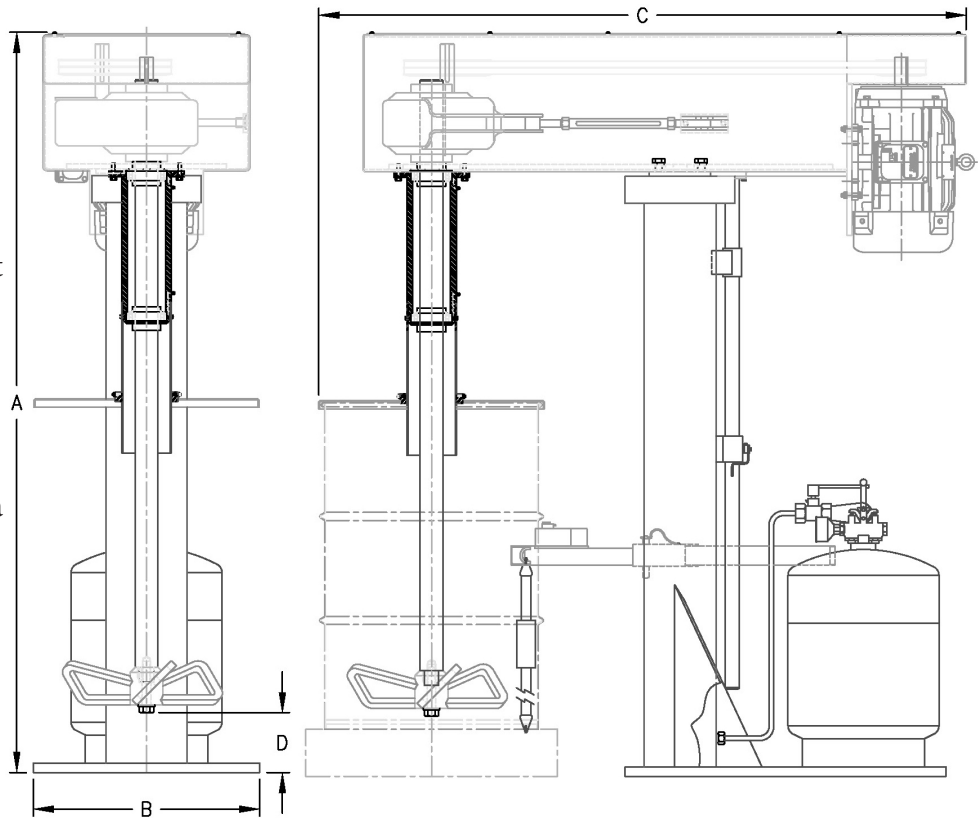

Model	HP	RPM	Capacity	Overall Length (C)		Overall Width		Overall Lowered Height (A)		Lowered Blade Clearance (D)		Raised Blade Clearance		Lift Rise		Shaft to Lift Distance		Weight
				Gallon	Inch	mm	Inch	mm	Inch	mm	Inch	mm	Inch	mm	Inch	mm	Inch	
PBA-5	5	44 - 175	5 - 150	55.75	1,416	24	610	79	2,005	6.5	165	54.5	1,385	48	1,219	24	610	1,900
PBA-7.5	7.5	44 - 175	5 - 250	55.75	1,416	24	610	79	2,005	6.5	165	54.5	1,385	48	1,219	24	610	2,000
PBA-10	10	44 - 175	50 - 500	55.75	1,416	24	610	79	2,005	6.5	165	54.5	1,385	48	1,219	24	610	2,100
PBA-15	15	44 - 175	50 - 500	55.75	1,416	24	610	79	2,005	6.5	165	54.5	1,385	48	1,219	24	610	2,200
PBA-20	20	44 - 175	50 - 500	55.75	1,416	26	660	90	2,285	9	230	63	1,600	48	1,219	24	610	2,300



CHARLES ROSS & SON COMPANY

P.O. Box 12308, 710 Old Willets Path, Hauppauge, NY 11788

• Telephone: 631-234-0500 • Fax: 631-234-0691

• Website: www.mixers.com • Email: sales@mixers.com